

SERVICE NOTICE

GENERAL CLASSIFICATION:

SN 276

Page 1 of 3

Specific Subject: Professional

Date Issued: 7/10/96

Battery Charger Recall

Introduction

On July 16, 1996, a press release will be issued to inform the public of a voluntary recall on four catalog numbers of battery chargers. In addition to the press release, posters will be distributed to all retail locations with information regarding the battery charger recall.

Customers will be instructed to bring their chargers to a Black & Decker Company Owned Service Center. Service Center Personnel will, at no charge, inspect the charger to identify the unit as affected or not affected. If found to be affected, the Service Center will execute a Type 6 Warranty Exchange for the corresponding part number based on the brand of charger (152203-00 for Black & Decker Industrial, and 152203-01 for the DeWALT brand charger).

There are 4 criteria that must all be confirmed in order to determine if the charger is affected. If any of the criteria is not fulfilled, the charger is not affected.

1. Catalog #'s:

<u>DeWALT</u>	<u>B&D Industrial</u>
DW9104	98014
DW9106	97014
152203-01	152203-00

2. Color:

Only Black Housing Chargers are affected units. (Yellow housing chargers are not affected by this recall)

3. Date Code:

9533 through 9615

4. Identifying Mark:

The affected chargers have a circular indentation about the size of a half dollar. This can be felt by rubbing your finger over the top of the nameplate. It can also be seen as you hold the unit at an angle to the light. (See Page 3)

If ANY of the above criteria is not fulfilled, the charger is not affected and not a part of this recall.

The potential problem with these chargers is that under sever conditions i.e. high impact, the chargers could crack and break apart. This condition is caused by several factors: 1) A substitute material that was used during this period of time due to a shortage of the original material 2) Screws that hold the unit together were found to be contaminated and caused a chemical reaction with the new plastic material that produced a less than acceptable holding power. 3) A flaw in one of the molds used during the date codes listed. Any one of these circumstances alone would never have caused this situation to arise, however, joined together, they produce a potential safety hazard. Because of this, Black & Decker is voluntarily recalling these units for replacement. There have been no injuries, reports, or claims against Black & Decker for this situation. As an act of good faith and proactive response to the situation we will execute the recall.

DO NOT ANSWER QUESTIONS FROM THE MEDIA! All immediate questions from the press or media regarding this situation must be deferred to Jean Miskimon at Eisner and Associates. The telephone number is (410) 625-2621. This number will be in effect until September 1, 1996. From that point forward, the contact for legal and press questions will be Jim O'Brien in the Legal Department at Black & Decker. Jim O'Brien's number is (410) 716-2575

Transaction Procedure

In-Center Exchange

When a customer has an affected unit that comes into your center you will execute a Type 6 Warranty Exchange with part # 152203-00 for B&D Chargers and 152203-01 for DeWALT Chargers. The affected charger is to be collected from the customer and stored for shipment to the NDC in Nashville. All chargers that are collected from the users are to be returned to the National Disposition Center in Nashville.

Out-of-Center Exchange

For customers who are not able to travel to a service center, or customers w/further questions, an 800# will be available. That number is 1-800-540-2626. Customers will be asked to identify if they have an affected unit. If they have an affected unit, they will be shipped a new unit directly from the 800# group. The customer will also receive a box with postage prepaid to send the affected charger back.

Authorized Servicrs will only be involved in distributing information on how to identify affected units, instructions to go to a company owned service center, or call the 800# provided.

All distributor concerns or questions should be directed to the 800# (800) 540-2626

Factory Outlets will not execute the exchanges under the recall. They will refer all customers to the nearest Service Center or to the 800# provided.

For all defective chargers that you exchange for your customers that are not part of this recall, you should continue to perform a Type 6 Warranty Exchange using the Accessory number. This will allow us to effectively track the return rate of the affected units.

Inventory

Each Service Center received one initial shipment of DeWALT Chargers (152203-01). You were instructed to NOT Acknowledge these units, but to do an account transfer to get these chargers into your inventory. All subsequent shipments are to be received as you would receive any other impress of inventory. Under these standard conditions, each Service Center was impressed one shipment of DeWALT chargers and one of Black & Decker chargers. **ANY ADDITIONAL CHARGERS REQUIRED TO HANDLE THIS RECALL WILL HAVE TO BE ORDERED BY EACH INDIVIDUAL CENTER THROUGH THE ISS AS A CODE 20 OR CODE 22.**

Questions

Any further questions pertaining to the recall not answered by this Service Notice should be referred to (410) 239-5144 or write to:

Battery Charger Recall
Black & Decker - Jim O'Brien
TW177
701 E. Joppa Rd.
Towson, MD. 21286

OR
Battery Charger Recall
Black & Decker - Keith Rogers
2nd Floor
626 Hanover Pike
Hampstead, MD. 21074

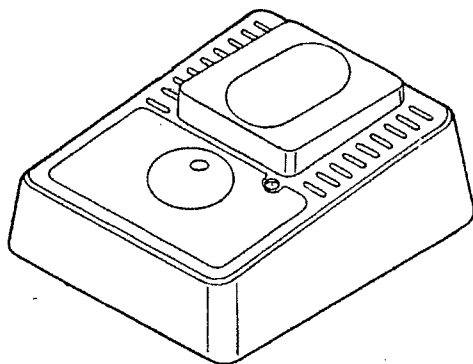

Affected Charger

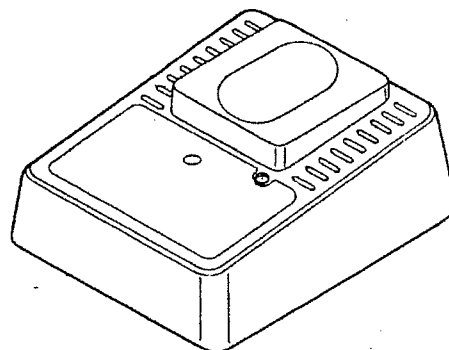

Not Affected

Must Have All Black Housings